

LIFTING CAPACITY

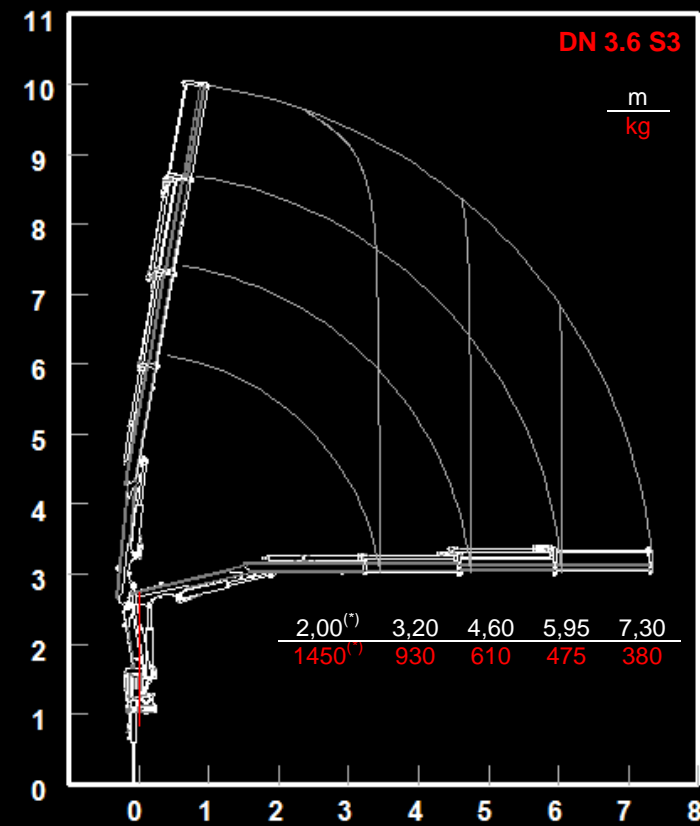

(\*) Capacity at fixed hook only with load limiting device

Portata al gancio fisso solo con limitatore di carico

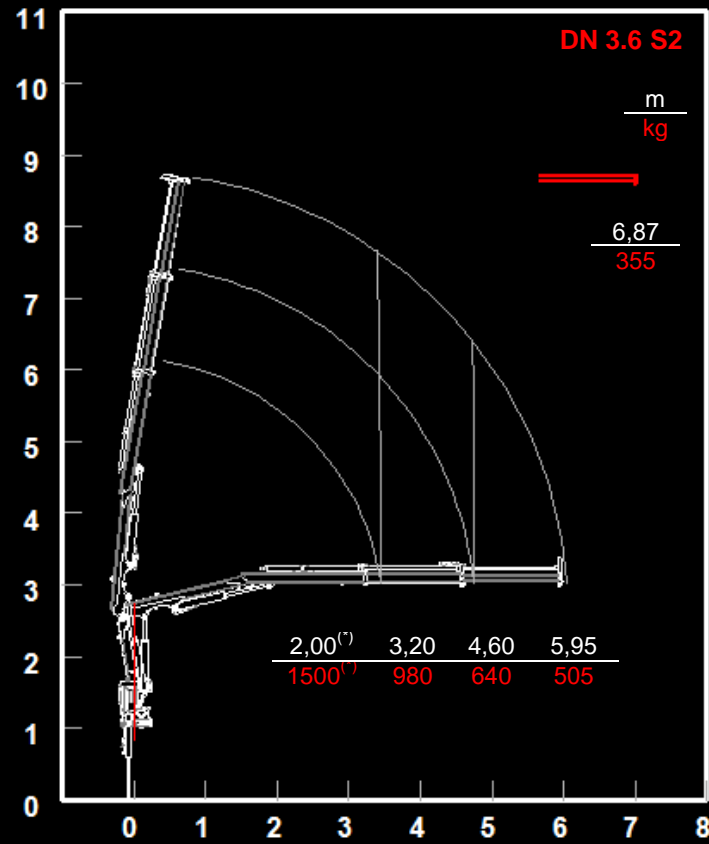
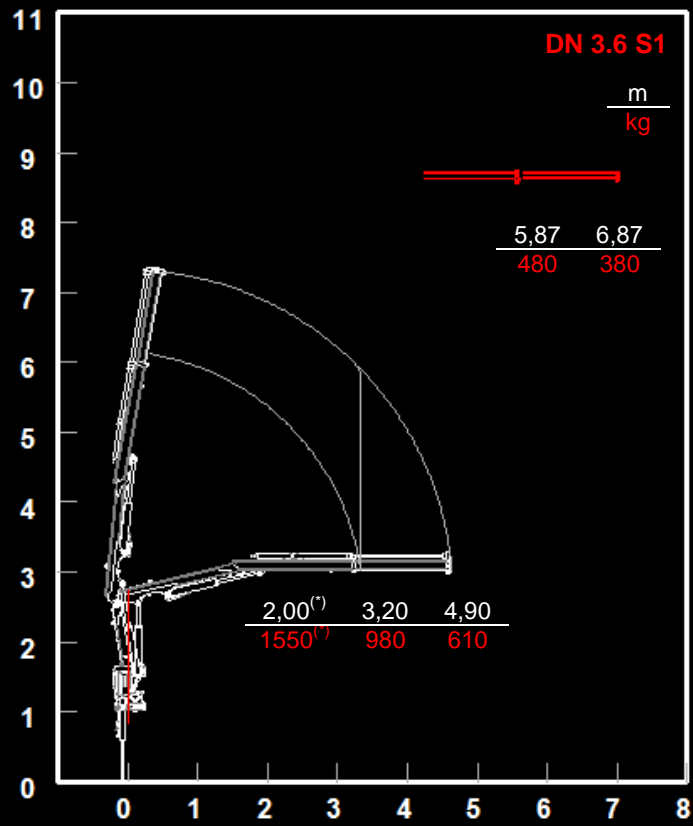

DN 3.6

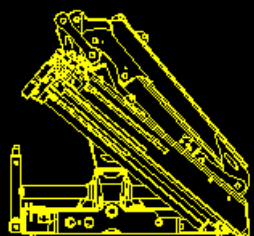

TECNICAL DESCRIPTION

- New concept product, extremely elaborate with advanced design
- 3 hydraulic extensions maximum and manual extensions optional
- Tilting stabilizers (optional)
- Special version DNN (DN Next) short boom version increase load capacity
- O-Ring oil joints
- Proportional distributor
- Sandblasted structure and high quality paint finish
- Slewing legs (optional)
- Flange valves on the cylinders
- Anti-corrosion treatment on all pins, joints and pipes
- Steel oil tank
- Additional options:
  - Distributor with 2 extra functions allows Rotor and accessory
  - PLE kit fully mounted and factory tested
  - Remote control
  - Winches



DALL'AGLIO NEWCRANES S.R.L.

Via Baghella, 160 46019 Viadana (MN) ITALIA

tel. +39 0375 480272

INFO LINE: +39 333 2273773



Autorized Distributor



www.dn Crane.com  
info@dn Cranes.com



## Caratteristiche del Prodotto

- Prodotto di nuova generazione estremamente curato e dal design evoluto
- 3 sfilii idraulici più eventuale prolunga manuale
- Stabilizzatori rotanti (optional)
- Versione speciale L Plus, gru dotata di tutti i più moderni controlli ottenuti mediante una efficiente ed affidabile gestione elettronica
- Versione speciale DNN (DN Next) aumenta l'altezza del gancio e la potenza delle gru in quella configurazione
- Raccordi idraulici con O-Ring
- Distributore proporzionale
- Carpenteria interamente sabbiata
- Stabilizzatori rotanti (optional)
- Valvole flangiate sui cilindri
- Tubi, raccordi, perni con trattamento anticorrosione
- Serbatoio dell'olio idraulico in acciaio
- Optional:
  - 2 attivazioni supplementari in punta per rotore ed attrezzo
  - Kit PLE installato e collaudato in fabbrica
  - Radiocomando
  - Argano



## Características del Producto

- Producto novedoso con diseño vanguardista y material de alta calidad
- 3 extensiones hidráulicas máximo, con la opción a una extensión manual
- Gatos estabilizadores rotatorios (opcional)
- Versión L Plus, sistema electrónico confiable monitorea todos los elementos de la grúa
- Versión especial DNN (DN Next) aumenta la altura bajo el gancho principal
- Empalmes O-Ring
- Distribuidor proporcional
- Tratamiento con sandblast en toda la estructura
- Gatos estabilizadores rotatorios (opcionales)
- Válvulas de bloqueo en todos los cilindros
- Tratamiento anti-corrosivo en todos los ejes, empalmes y tuberías
- Tanque de aceite en acero
- Opciones adicionales:
  - Distribuidor con 2 funciones extras rotor/accessorio
  - Kit PLE instalado y certificado en planta
  - Radio control
  - Cabrestante



## Caractéristiques du Produit

- Produit de nouvelle conception extrêmement soigné et au design évolué
- Jusque 3 extensions hydrauliques et eventuelle rallonge manuelle
- Stabilisateurs rotatifs en option
- Grue en version L Plus. Grue avec gestion électronique efficace et fiable de tous les éléments de la grue
- Version spéciale bras court DNN (DN Next) augmente la hauteur sous crochet et la puissance de la grue dans cette configuration
- Raccords huile O-Ring
- Distributer proportionnel
- Structure de la grue entièrement sablée
- Stabilisateurs rotatifs en option
- Valves flasquées sur les vérins
- Tuyaux, axes et raccords traités anticorrosion
- Réservoir d'huile en acier
- Options disponibles:
  - Distributeur activés pour 2 éléments supplémentaires rotor et accessoire
  - Kit PLE monté et homologué en usine
  - Radiocommande
  - Treuil



## Basis Daten

- Neues extrem sorgfältiges Produkt mit kunstvoll gearbeitetem Design
- Bis 3 hydraulischen ausschüben und optional manuelle armverlängerung
- Rotationsstabilisatoren in optional
- Die L Plus ausführung bietet eine elektronische effektive und zuverlässige steuerung aller kranelemente an
- Die DNN (DN Next) spezialausführung mit verkürztem arm leistet, es steigert die hakenhöhe sowie die kraftleistung des kranes
- Ölanschlussgewinde mit O-Ring
- Proportionalsteuerblock
- Optional: schwenkbare abstützungen
- Kranstahlbauteile werden alle sandstrahlt
- Zylinder mit Ventilen ausgerüstet
- Achse und schäuche sind gegen korrosion geschützt
- Stahl öl tank
- Verfügbare optionen:
  - Distributor zwei extraelementen, die für einen rotor und zubehörteil aktiviert sind
  - Einrichtung einer von der fabrik anerkannten Kit PLE (mobile elevating work platforms) ausrüstung
  - Funkfernsteuerung
  - Seilwinde

## STANDARD CRANE

### Standard Outrigger Beams

Bracci stabilizzatori standard - Brazo estabilizadores - Bras de stabilisation standard - Standardstützarme

2,7 m

### Rotation Angle

Angolo di rotazione - Angulo de rotación - Angle de rotation - Schwenkbereich

365°

### Recommended Oil Flow

Portata olio raccomandata - Caudal requerido - Débit recommandé - Empfohlene Fördermenge

10 l/min

### Oil Tank Capacity

Capacità del serbatoio - Capacidad del tanque de aceite - Capacité du réservoir d'huile - Öl tankinhalt

30 l

### Maximum Pressure

Pressione massima - Presión máxima - Pression maximum - Maximal zulässiger betriebsdruck

280 bar

### Tierods About Anchorage

Tiranti di ancoraggio - Tirantes de fijación - Ancrage de fixation - Zugstangen verankerzubehörs

N.6 - M18x1,5  
39 NiCrMo3

## DN 3.6

S1

S2

S3

### Overhung crane with empty oil tank

Massa della gru senza olio nel serbatoio

410 kg

425 kg

450 kg

Peso della grúa sin aceite en el depósito

Poids de la grue sans huile dans le réservoir

Gewichte des kranes ohne öl im tank

### Maximum lifting moment

Momento di sollevamento massimo

3,1 t/m

3,0 t/m

2,9 t/m

Momento de elevación máximo

Moment de leverage maximum

Schwenkmoment

### Hydraulic reach

Sbraccio oleodinamico

4,9 m (\*)

5,95m (\*)

7,3 m (\*)

Alcance hidráulico

7,3 m (\*\*)

8,8 m (\*\*)

9,7 m (\*\*)

Allongement hydraulique

Hydraulische reichweite

## MAIN DIMENSIONS

