

Lifting Capacity

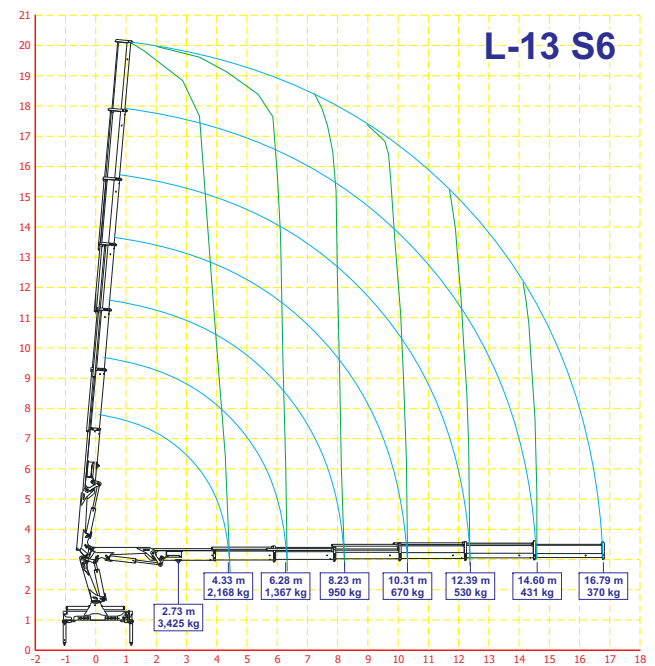

L-13

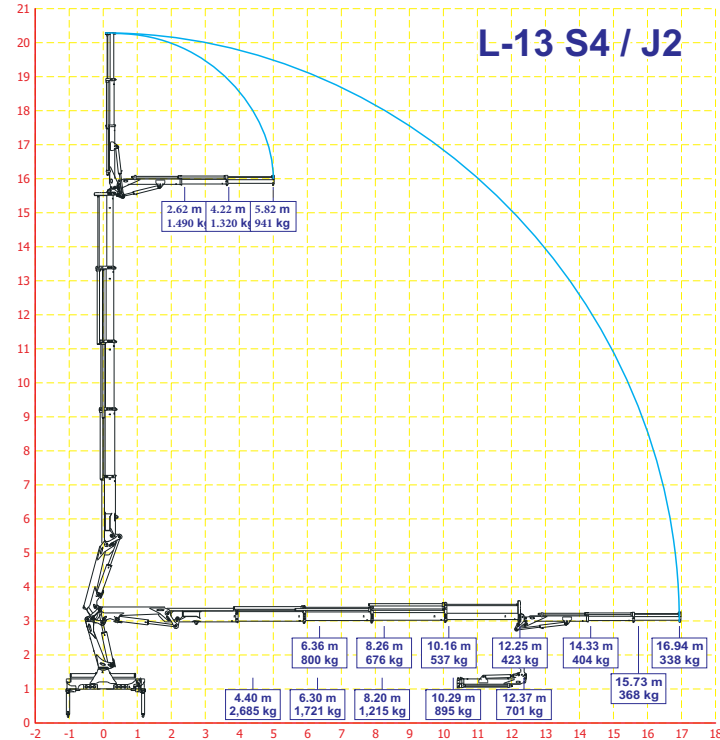
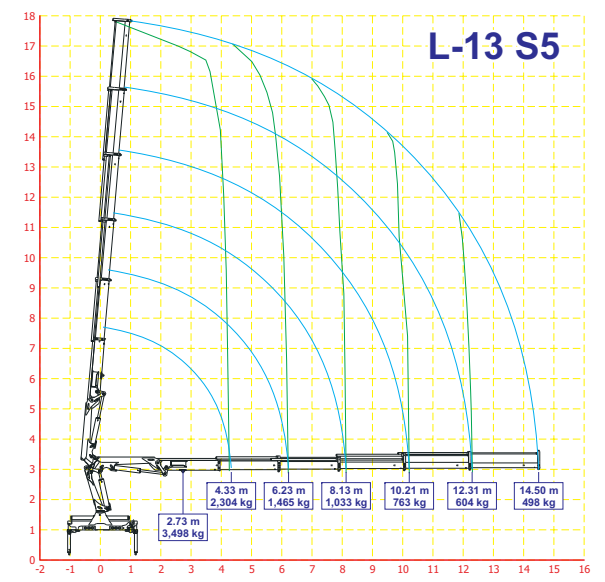

<http://www.dncrane.com>
info@dncranes.com

DALL'AGLIO NEWCRANES S.R.L.

Via Baghella, 160 46019 Viadana (MN) ITALIA

tel. +39 0375 480272

INFO LINE: +39 333 2273773

Authorized Distributor

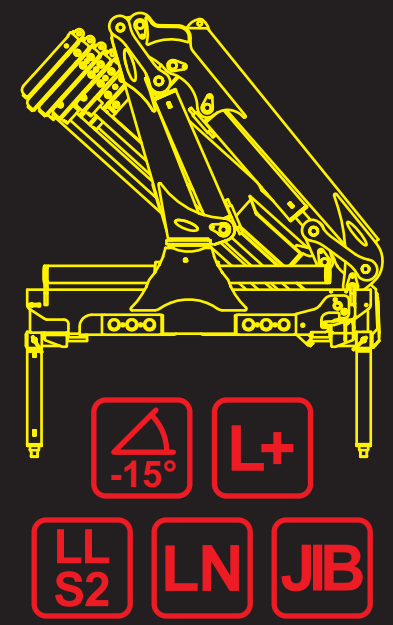

TECHNICAL DESCRIPTION

- 6 Hydraulic extensions - maximum and manual extension (optional)
- Large opening stabilizers to install on 12 ton trucks Optional
- 15° negative angle on the second boom
- L Plus version available - advanced electronic control system monitors the unit
- DNLS 2 (DN Link System) New Power System increases the crane capacity
- Special Version DNN (DN Next) short boom version increases load capacity
- Flying JIB version for 2 or 3 extensions available
- O-Ring oil joints
- Proportional distributor
- Sandblasted structure and high quality paint finish
- Slewing legs (optional)
- Flange valves on the cylinders
- Anti-Corrosion treatment on all pins, joints and pipes
- Steel Oil tank
- Additional Options:
 - Distributor with 2 extra functions allows Rotor and accessory
 - PLE kit fully mounted and factory tested
 - Remote control
 - Winches



www.dncrane.com
info@dncranes.com

